

BF150
FRIDGE WITH ICEBOX

Instruction manual

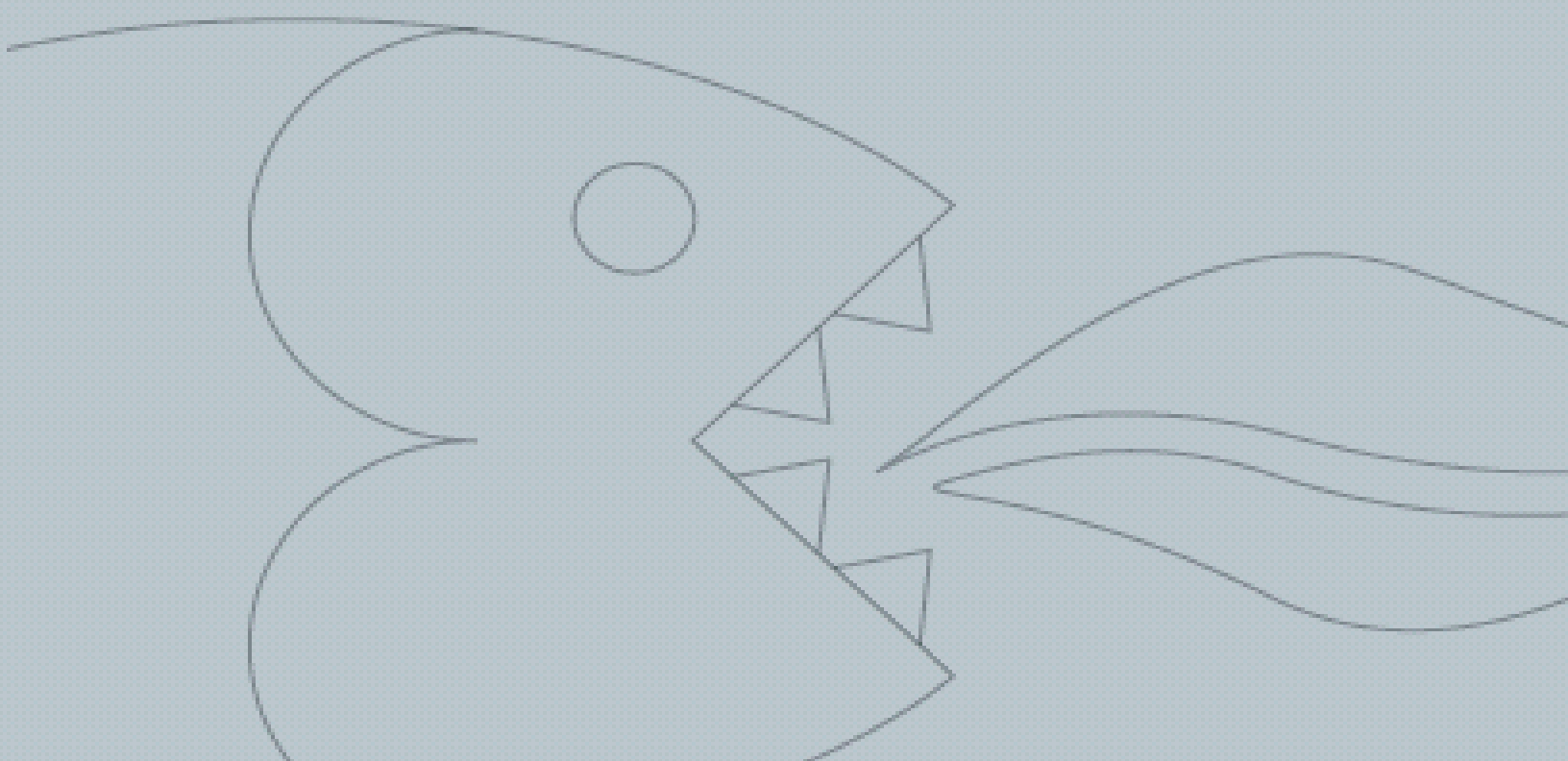

User Manual for your
BF150
UNDER-COUNTER FRIDGE
WITH ICEBOX



NOTE: This User Instruction Manual contains important information, including safety & installation points, which will enable you to get the most out of your appliance. Please keep it in a safe place so that it is easily available for future reference.

CONTENTS

YOUR FRIDGE-FREEZER'S SPECIFICATIONS3

SAFETY INFORMATION / ENVIRONMENTAL NOTE .. 4

USING YOUR FRIDGE.....5-12

YOUR BF150 FRIDGE.....5

BEFORE USING YOUR FRIDGE6

USING YOUR FRIDGE7-10

CLEANING AND MAINTENANCE.....11

DEFROSTING12

INSTALLING YOUR FRIDGE-FREEZER.....13

HOW TO REVERSE THE DOOR SWING14

TROUBLESHOOTING16

CONDITIONS OF GUARANTEE.....17

CONTACT DETAILS.....18

Specifications of your BF150 Fridge

Congratulations on purchasing a Baumatic BF150 Under-counter Fridge with Icebox!

Your Larder-Fridge has:

- ***Gross capacity: 150 litres***
- ***Net capacity (fridge / freezer): 100/15 litres***
- ***Energy efficiency class: B***
- ***Star rating: *****
- ***Automatic Fridge Defrost***
- ***Adjustable Thermostat***
- ***Icebox***
- ***Freezer compartment***
- ***2 Wire Shelves***
- ***Salad Crisper***
- ***Reversible Door***
- ***Adjustable Feet***

Dimensions mm (H x W x D)

840 x 500 x 558

To fully enjoy using your appliance long into the future, please firstly familiarise yourself with the specifications, safety advice and operational instructions included in this manual.

NOTE:

When you install your Fridge, it is important to bear in mind its climatic rating.

In order to find out the climatic rating of your appliance, check the data rating tag inside your refrigerator. It indicates the ambient temperature range within which your appliance will function.

Important Safety Information: Please Read this before installing & using.

ELECTRICAL SAFETY

 This appliance complies with Directives 89/368/EEC, 73/23/EEC and following changes.

- **NOTE** - This appliance must be grounded. In the event of a malfunction or breakdown, grounding will reduce the risk of electric shock by providing a path of least resistance of electrical current. You will be able to tell if it is because a non-grounded appliance will give off an electrical discharge. **Manufacturer declines all responsibility for any damage due to non-grounding of appliance.**
 - DURING THE GUARANTEE PERIOD ONLY BAUMATIC SERVICE ENGINEERS OR AN AUTHORISED AGENT OF BAUMATIC SHOULD CARRY OUT REPAIRS ON THIS UNIT.
 - DO NOT USE IF THE SUPPLY CORD IS DAMAGED. NEVER TAKE RISKS WITH FIRE!
- ENSURE YOU CONNECT THIS APPLIANCE TO A SUPPLY RATED AT 220-240V (or 200-230V) and 50HZ.
- **NOTE:** the supporting structure is constructed in panels of treated sheet steel, electrostatically enamelled to resist ill-treatment and to give long-lasting beauty and shine.

 Do not attempt to alter the specifications of this appliance. Doing so could damage the machine, cause injury & invalidate your warranty. DO NOT USE ADAPTERS/SHUNTS.

 Do not allow children to play with, near or inside this Fridge-Freezer.

 Do not pull on the power supply cable to free the plug from the wall!

 Do not attempt to use your Fridge-Freezer outdoors or any place where it is likely to come into contact with the elements.

 Do not pull out or insert the plug with wet hands.

 Before any cleaning or maintenance work, ensure that the appliance has been disconnected from the power supply.

 Never allow the back coils of the Fridge-freezer to come into contact with any wall surface. ALWAYS ENSURE THAT THE SPACE INTO WHICH YOU ARE PLACING YOUR APPLIANCE IS FREE OF STORED ITEMS SUCH AS PAPERS OR OTHER FLAMMABLE MATERIALS.

 NEVER block the VENTILATION OPENINGS OF THE APPLIANCE EITHER INSIDE OR ON ITS EXTERIOR. IT IS VITAL TO KEEP YOUR FRIDGE-FREEZER WELL VENTILATED SO THAT THERE IS PROPER AIR FLOW BETWEEN THE BOTTOM OF THE UNIT AND THE PLINTH / KICK PLATE ON WHICH IT IS SITTING.

 WARNING – DO NOT DAMAGE THE REFRIGERANT CIRCUIT. AT THE END OF THE FUNCTIONAL LIFE OF THE EQUIPMENT (WHICH USES COOLING GAS R600a [ISOBUTANE]) AND INFLAMMABLE GAS INSIDE THE INSULATING FOAM, IT MUST BE PLACED IN SAFETY BEFORE SENDING IT FOR PROPER WASTE DISPOSAL.

PLEASE OBSERVE ALL INSTALLATION ADVICE IN THIS MANUAL FOR SAFE USAGE OF YOUR APPLIANCE.

Note: Before discarding an old refrigerator/freezer, switch off and disconnect it from the power supply. Cut off and render any plug useless. Ensure that the door cannot jam (removing it is best), regardless of whether or not it can be pushed open from inside. AN OLD FRIDGE/FREEZER CAN BE A DEADLY PLAYTHING FOR CHILDREN!

CONFORMITY TO W.E.E.E. DIRECTIVE

This appliance is marked according to the European directive 2002/96/EC on Waste electrical and Electronic Equipment (WEEE). By ensuring this product is disposed of correctly, you will help prevent potential negative consequences for the environment and human health, which could otherwise be caused by inappropriate waste handling of this product.

The symbol  on the product, or on the documents accompanying the product, indicates that this appliance may not be treated as household waste. Instead it shall be handed over to the applicable collection point for the recycling of electrical and electronic equipment.

Disposal must be carried out in accordance with local environmental regulations for waste disposal. For more detailed information about treatment, recovery and recycling of this product, please contact your local city office, your household waste disposal service or the shop where you purchased the product.

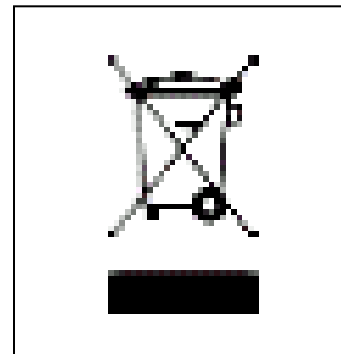

Using your Baumatic BF150 FRIDGE:

Your BF150 UNDER-COUNTER FRIDGE WITH ICEBOX:

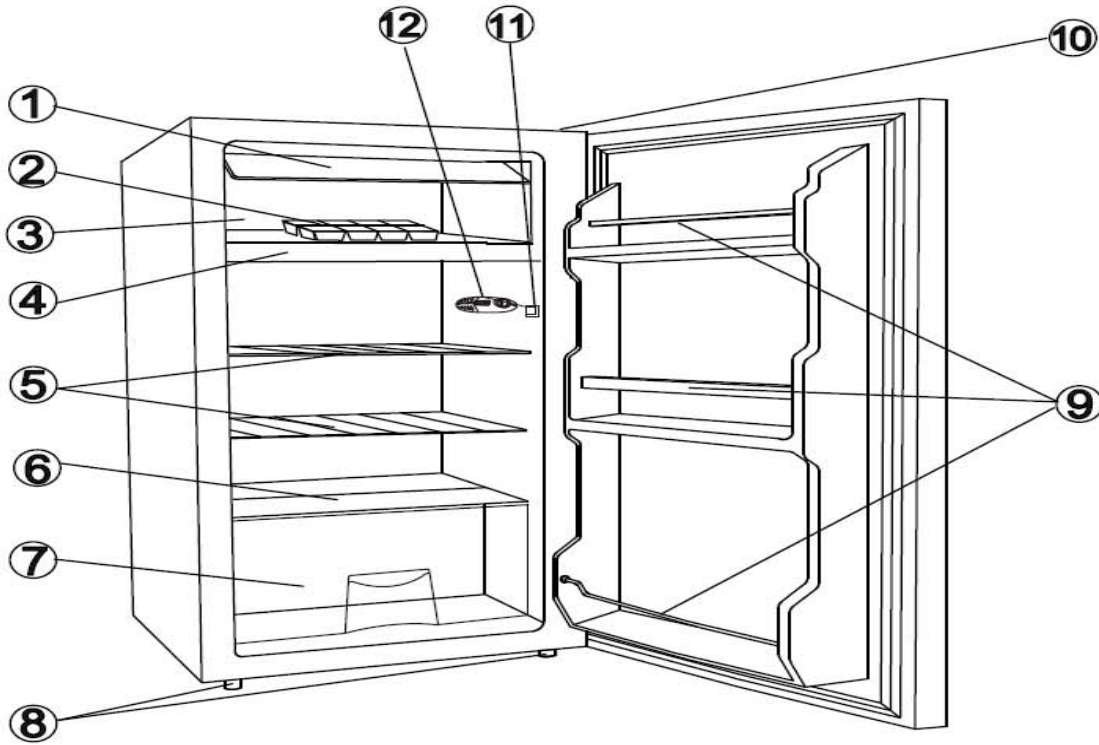

- ① Freezer Compartment Door
- ② Ice Cube Tray
- ③ Freezer Compartment
- ④ Drip Tray
- ⑤ Shelves of refrigerator chamber
- ⑥ Glass cover
- ⑦ Crisper box
- ⑧ Leveling Legs
- ⑨ Bottle Racks
- ⑩ Recessed Handle
- ⑪ Door switch
- ⑫ Temperature Control Knob

NOTE: BEFORE Using your BF150 FRIDGE:

UPON DELIVERY:

When your Fridge has been delivered, you will need to wait approximately 2 hours before turning it on. The fluid of the compressor installed in the appliance will need time to settle. **PLEASE DO NOT PLUG IN ANY EARLIER THAN THIS!**

NOTE:

THERE CAN BE AN ODOUR WHEN YOU FIRST SWITCH ON THE APPLIANCE. IT WILL VANISH WHEN THE UNIT STARTS COOLING.

We recommend that you have the Fridge delivered near to where you plan to install it so that this fluid can settle.

SITUATING YOUR FRIDGE

CAUTION: DO NOT PLACE THE APPLIANCE NEAR HEAT SOURCES AND LEAVE AT LEAST 5CM OF SPACE ABOVE THE UPPER SECTION.

FOR FULL INSTALLATION ADVICE, PLEASE SEE PAGE 13

MAKE A NOTE OF THE LOCATION FOR YOUR NEW FRIDGE. MAKE SURE THAT IT WILL FIT PROPERLY SO THAT:

- 1) The doors can open freely and completely.
- 2) You can access your food conveniently.
- 3) There is sufficient space at the back for the cooling coils to give off heat safely & that they do not touch the plug (see SAFETY SECTION).

NOTE: You can reverse the swing of the door to customise the unit to your location. Please see page 14 for details.

USING your Baumatic BF150 FRIDGE:

YOU SWITCH ON YOUR APPLIANCE by **PLUGGING IT IN & SETTING THE THERMOSTAT** inside the Fridge at the top right-hand side ('12' in Key on Page 5). It looks like this:

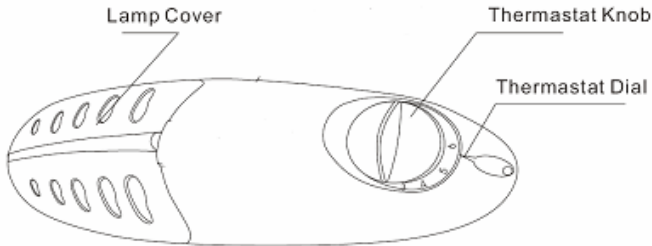

The thermostat automatically regulates the inside temperature of the compartments. By rotating the thermostat knob from a low to a higher position, colder temperatures can be obtained.

Refrigerator Thermostat setting:

Low: Use this setting for short-term storage of food in the fridge – mild coldness. **Mid:** Use this setting for longer storage of food in the fridge – mid coldness. **High:** Use this setting to get the coldest possible temperature.

NOTE: *On the maximum setting, your fridge will work harder to maintain this low temperature so after you reach this temperature, you should turn the knob to a milder setting (depending on long or short-term storage intentions).*

USING your Baumatic BF150

Reminder: Allow the unit time to settle after delivery. If your plug and power socket are now behind the fridge and you still need to move the unit into place, be especially careful: Remember to leave a safe distance between the back of the fridge and the wall.

- **You switch your fridge OFF by turning the thermostat knob to position '0'.**

MAKING ICE CUBES

Pour water into the Ice cube tray. Fill to $\frac{3}{4}$ full in each cell of the tray then place the tray in the freezer compartment.

Do not use a knife or other metal tools to take ice out of the tray once ice has been made.

Ice can easily be removed by hand after the tray has been placed in warm water for a short time.

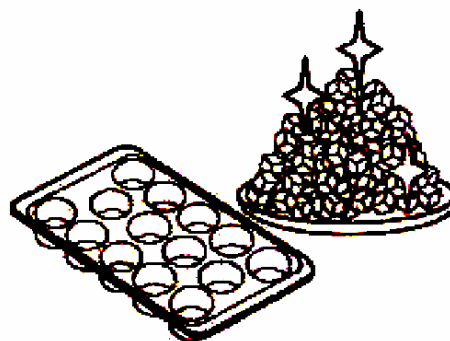

NOTE: When you first switch on the appliance, allow 24 hours for it to cool down to the desired temperature. During this time, DO NOT open the door often or place a lot of food inside the unit.

WARNING! If the appliance is switched off then switched back on again after a short period, the compressor will start up again after approximately half-an-hour. This is part of the normal operation of the appliance.

ARRANGING FOOD IN YOUR FRIDGE

- *To reduce humidity and the consequent increase of frost, NEVER place liquids in unsealed containers in the refrigerator. Frost tends to concentrate in the coldest parts of the evaporator. In time, the unit will need more frequent defrosting if too much humidity develops inside it.*
- *NEVER place warm food inside the refrigerator. Warm food must be allowed to cool at room temperature. It should then be arranged to ensure adequate air circulation in the refrigerator compartment.*
- *DO NOT ALLOW anything to touch the refrigerator's back wall as it will cause frost. Also, packaging, especially paper, can stick to it and spoil.*
- *DO NOT open the refrigerator door too often or leave it open for long spells of time.*
- *ARRANGE meat and cleaned fish (wrapped in packages or sheets of plastic) which you will then use within 1-2 days.*
- *You can put fruits and vegetables into the crisper without packing them.*
- *Use the egg holders provided in the door space to store your eggs.*

NOTES ON USING YOUR FRIDGE

ALWAYS Cover and wrap foods, especially if they are PUNGENT.

- DO NOT place paper or plastic on the shelves which would block the flow of air through the grids.

NOTE: At the maximum cold setting, with a high outside (ambient) temperature and well-stocked (full or nearly full) compartments, the Fridge's operation may be continuous, leading to the formation of some frost on the evaporator.

Should this happen, the knob must be turned to a less cold position to allow automatic defrosting.

This will also allow lower energy consumption.

REMINDER: *You should regulate the temperature of your Fridge bearing the following in mind:*

- Ambient temperature
- How often the doors are opened and closed
- Quantity of food stored in the compartments
- Moisture content of what you place in your fridge
- The location of your appliance

IN CASE OF A BLACKOUT (GENERAL POWER FAILURE)

In case of Power Failure, find out how long the electricity will be off. If the failure is not going to be for any longer than 12 hours, leave the food in the freezer and keep the door closed.

If the POWER FAILURE is going to last longer than 12 hours and some food defrosts, consume the latter as soon as possible.

LONG ABSENCES (vacations, etc.): In the case of long absences, the appliance must be switched off, emptied out completely, dried and the doors left open to prevent the formation of mould and unpleasant odours.

CLEANING / MAINTENANCE

NOTE: Before attempting to clean your Fridge, UNPLUG IT and make sure you do the following:

WE RECOMMEND THAT YOU CLEAN AND MAINTAIN YOUR REFRIGERATOR ONCE A MONTH.

- ✓ Pay particular attention to the sealing rubber bars of the doors. These need to be kept clean for hygienic reasons as well as to allow the door to close properly.
- ✓ Leave the door open.
- ✓ In order to collect the defrosted water, take out the bottom drawer and soak up the water using a sponge as shown in the figure pictured below.



To accelerate the defrosting process, you can scrape off any frost that may have formed using a plastic spatula.

DO NOT USE A METAL ONE!!!!

- ✓ Clean the inside of your Fridge using a solution of soda bicarbonate in warm water (1 tablespoon Bicarbonate to 2 litres of water).

NEVER USE SOLVENTS TO CLEAN THE INSIDE OF YOUR FRIDGE or ICEBOX.

MAINTENANCE FROM TIME TO TIME, YOU WILL NEED TO REPLACE THE INTERNAL BULB. REMEMBER TO UNPLUG YOU APPLIANCE FIRST

Find the lamp housing in the top right of the refrigerator's interior.

Gently move the transparent lamp cover plate from the lamp cradle.

Unscrew the bulb and replace with a new one, being mindful of the wattage maximum.

DEFROSTING

Defrosting occurs fully automatically in the refrigerator compartment during normal operation. The defrosted water collected by the evaporating tray evaporates automatically.

However, you will have to manually defrost the freezing compartment (icebox) when the frost and ice layer coating its interior is 3-5mm.

You do this by:

- 1) Turning the thermostat knob to the STOP (0) position and disconnecting the power supply.
- 2) Emptying the icebox, taking care that the packages remain frozen by wrapping them properly.
- 3) Mopping up melted water from the bottom of the appliance with a cloth.

Avoid using defrosting sprays, as they may cause damage to the plastic parts and may be hazardous to health.

NOTE: The evaporating tray & water drain hole should be cleaned periodically with a plastic straw to prevent water from collecting on the bottom of the refrigerator instead of flowing out.

INSTALLATION INSTRUCTIONS – BF150 FRIDGE

- 1) Ensure that you are going to be placing your fridge away from heat sources and in a well-ventilated position. This should be at least 50 cm from radiators, gas or coal stoves and 5 cm away from electric stoves. Do not place the appliance in the path of direct sunlight.
- 2) Make sure that the plug is accessible after positioning your fridge.
- 3) Keep a space of 15cm above your fridge and at least 10cm behind it.
- 4) If placing beside another refrigerator or freezer, keep at least 2cm between the units to prevent condensation.
- 5) Gently move the appliance into place or, in the case of installing in a unit, into its housing.
- 6) Adjust the feet (see picture at right) until your Fridge sits levelly on your floor. You can level your unit using these adjustable feet to compensate for dips and rises in your floor surface.

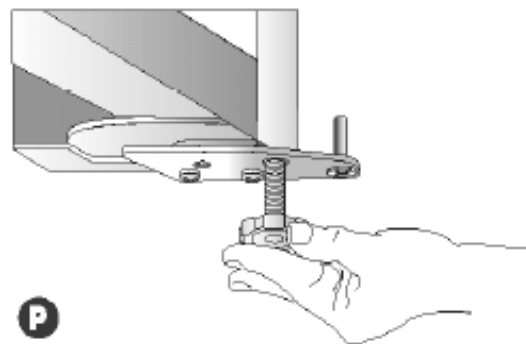

REVERSING THE DOOR OPENING (swing of the door):

Ensure there is sufficient space behind the cooling coils at the back of your Fridge – 12.7cm (5") is ideal!

- 1) Remove the screws (6) which fix the steel plate (10).
- 2) Take away the steel plate (10) and lift the door. Put the door on a soft surface to keep it from getting scratched.
- 3) Remove the two screws (8) that hold the lower hinge (2) and make sure to remove the lower hinge (2).
- 4) Take off the front left leg (4) and transfer it to the right side.
- 5) Before placing this lower hinge (2), remove the bolt-pin (9) and reverse the direction of the lower hinge (2). Then install the lower hinge (2) onto the left side of the lower frame with two screws (8).
- 6) Insert the bolt-pin (9) into the lower hinge (2).
- 7) Take off the upper hinge (7) on the right hand side of the steel plate (10) and install the upper hinge (7) on the left side of the steel plate (10).
- 8) Set the door in place making sure the door seats into the lower hinge (2).
- 9) While holding the door closed, put the upper hinge (7) into the door hinge hole and secure the steel plate (10) in the top frame with the screws (6). Please remember not to tighten the screws (6) until the top of the door is levelled with the counter top.

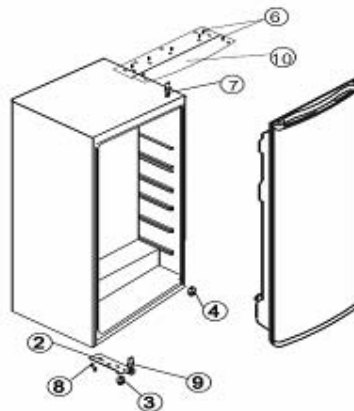
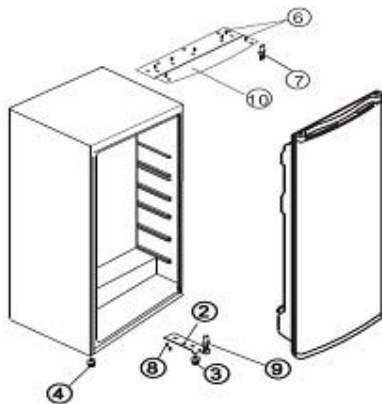

Installation- continued

YOU MUST install this appliance in a well ventilated, dry room.

Energy use is affected by the ambient temperature.

You are therefore advised to:

- Not expose the appliance to direct sunlight;
- Not install the appliance next to radiators, cookers or other sources of heat;
- Only install the appliance at a location whose ambient temperature corresponds to the climate classification, for which the appliance is designed.

The climate classification can be found on the data rating tag, which is located at the left on the inside of the appliance.

Cooling Temperature Ranges

Climate Classification	Recommended Ambient Temp.
SN	+10 to +32° C
N	+16 to +32° C
ST	+18 to +38° C
T	+18 to +43° C

If the appliance is installed next to another refrigerator or freezer a clearance of 5 cm at the side is required. This is to prevent the formation of condensation on the outside of the appliance.

Troubleshooting

Trace a problem using the table below instead of having to call for help.

PROBLEM	WHAT TO DO
YOUR FRIDGE DOES NOT APPEAR TO BE WORKING / NO APPARENT POWER	CHECK THAT THE PLUG IS WELL-INSERTED INTO THE POWER SOCKET
	CHECK THAT THERE IS POWER FROM THE MAINS – THERE MAY BE A BLACKOUT OR YOUR FUSES MAY HAVE BLOWN.
	CHECK THAT THE ELECTRONIC THERMOSTAT (REGULATOR FOUND ON THE INSIDE WALL OF THE FRIDGE NEAR THE TOP) IS IN THE RECOMMENDED FUNCTIONING POSITION AND NOT '0' (OFF).
	CHECK THAT THE SOCKET IS SUFFICIENT AND NO ADAPTER OR EXTENSION LEADS HAVE BEEN USED.
	CHECK THAT THE POWER SUPPLY VOLTAGE CORRESPONDS TO THE APPLIANCE.
YOUR FRIDGE APPEARS TO BE PERFORMING POORLY	YOU HAVE OVERLOADED THE APPLIANCE OR FOOD HAS BEEN PACKED TOO TIGHTLY. TAKE OUT AND CONSUME FOOD; LOOK FOR OUT-OF-DATE FOOD THAT CAN BE DISPOSED OF.
	THE THERMOSTAT SETTING IS SET TOO LOW. SET IT HIGHER.
	ENSURE THAT THE DOOR HAS BEEN CLOSED PROPERLY. FOR INSTANCE, THERE MAY BE A PROBLEM INSIDE THE UNIT, KEEPING THE DOOR OPEN OR ANOTHER FAULT, SUCH AS A BROKEN OR MISSING DOOR SEAL.
	ENSURE THAT THERE IS NO DUST ON THE CONDENSER.
	ENSURE THAT THERE IS ENOUGH ROOM AT THE REAR AND SIDES OF THE UNIT.
THERE IS A NOISE	<p>THE COOLING GAS WHICH CIRCULATES MAY MAKE A SLIGHT NOISE (BUBBLING SOUND) EVEN WHEN THE COMPRESSOR IS NOT RUNNING. THIS IS NORMAL. IF THESE SOUNDS CHANGE, ENSURE:</p> <p>YOUR UNIT IS WELL LEVELLED / NOTHING IS TOUCHING THE REAR OF THE UNIT / NO MATERIAL ON THE APPLIANCE IS VIBRATING.</p> <p>NOTE: A SOUND LIKE FLOWING WATER IS PERFECTLY NATURAL AS IT INDICATES THAT THE REFRIGERANT IS FLOWING. THIS IS NOT A MALFUNCTION.</p>

ADDITIONAL NOTE: SHOULD THE CABINET'S SIDE PANEL HEAT UP, THIS IS NORMAL. IT WILL DO THIS IN SUMMER WITH A HIGH AMBIENT TEMPERATURE OR IF THE DOOR HAS BEEN OPENED AND CLOSED FREQUENTLY. IT IS THE RESULT OF HEAT'S DISSIPATING FROM INSIDE THE CABINET AND IS NOT DETRIMENTAL TO YOUR REFRIGERATOR IN ANY WAY.

BAUMATIC LTD. -CONDITIONS OF GUARANTEE.

Dear Customer,

The conditions of guarantee which apply to your Baumatic appliance are as follows: This product is guaranteed for 12 months from the date of original purchase. Baumatic Ltd will repair any defect that arises due to faulty materials or workmanship free of charge during this period.

*In addition, your appliance is covered by a 5 year parts warranty. Baumatic Ltd will provide free of charge the parts required to repair the appliance, only if they are fitted by a Baumatic engineer, for any defect that arises due to faulty materials or workmanship within a period of 5 years from the original purchase date.

*An additional and annually renewable insurance scheme for labour is available should you wish to extend the warranty period.

Should any person other than an authorised representative of Baumatic Ltd interfere with the appliance, the policy is negated and Baumatic Ltd will be under no further liability.

The guarantee covers the appliance for normal domestic use only, unless otherwise stated.

Any claims made under the terms of the guarantee must be supported by the original invoice/bill of sale issued at the time of purchase.

This guarantee is transferable only with the written consent of Baumatic Ltd.

If the appliance fails and is considered either not repairable or uneconomical to repair between twelve months and five years from purchase date, a free of charge replacement will not be offered.

The guarantee for any replacement will only be for the remainder of the guarantee on the original product purchased.

This guarantee does not cover:

x Sinks and taps

X Failure to comply with the manufacturer's instructions for use.

X The replacement of cosmetic components or accessories.

X Accidental damage or wilful abuse.

X Subsequent loss or damage owing to the failure of the appliance or electrical supply.

X Incorrect installation.

X Losses caused by Acts of God, civil war, failure to obtain spare parts, strikes or lockouts.

X Filters, fuses, light bulbs, external hoses, damage to bodywork, paintwork, plastic items, covers, baskets, trays, shelves, burner bases, burner caps, decals, corrosion, rubber seals..

In the course of the work carried out it may be necessary to remove the appliance from its operating position. Whilst all reasonable care will be taken, Baumatic Ltd cannot accept responsibility for damage sustained to any property whatsoever in this process.

This guarantee is in addition to and does not diminish your statutory or legal rights.

Contacting Baumatic.

SALES

TEL: 0118 933 6900

FAX: 0118 931 0035

SERVICE

TEL: 0118 933 6911

FAX: 0118 986 9124

SPARES

TEL: 0118 933 6922

FAX: 0118 933 6942

TECHNICAL / ADVICE

TEL: 0118 9336933

FAX: 0118 9336942

For mainland UK and Northern Ireland, please contact one of the above numbers for further information or any other query you may have.

For ROI (Republic of Ireland), please contact one the numbers below:

TEL: 01 - 6266798 FAX: 01 - 6266634

Thank you for buying Baumatic.

*Applies to UK, Scotland, Wales & Northern Ireland only. (Republic of Ireland has 1 year labour and 1 year parts warranty only) .

Baumatic Ltd

Make-up for your kitchen

Headquarters

Baumatic Ltd.
Baumatic Buildings,
6 Bennet Road,
Reading,
Berkshire
RG2 0QX, United Kingdom

Sales Telephone
+44 118 933 6900

Sales Fax
+44 118 931 0035

Service Telephone
+44 118 933 6911

Service Fax
+44 118 986 9124

Spares Telephone
+44 118 933 6922

Technical / Advice Telephone
+44 118 933 6933

E-mail:

sales@baumatic.co.uk

technical@baumatic.co.uk

Http (Internet site):
www.baumatic.com

Baumatic UK/cod. 1230000666

NOTE YOUR APPLIANCE DETAILS HERE:

DATE _____

DEALER:

ADDRESS:

SERIAL NUMBER:



Baumatic®

www.baumatic.com