

BTM25.2M

Instruction manual

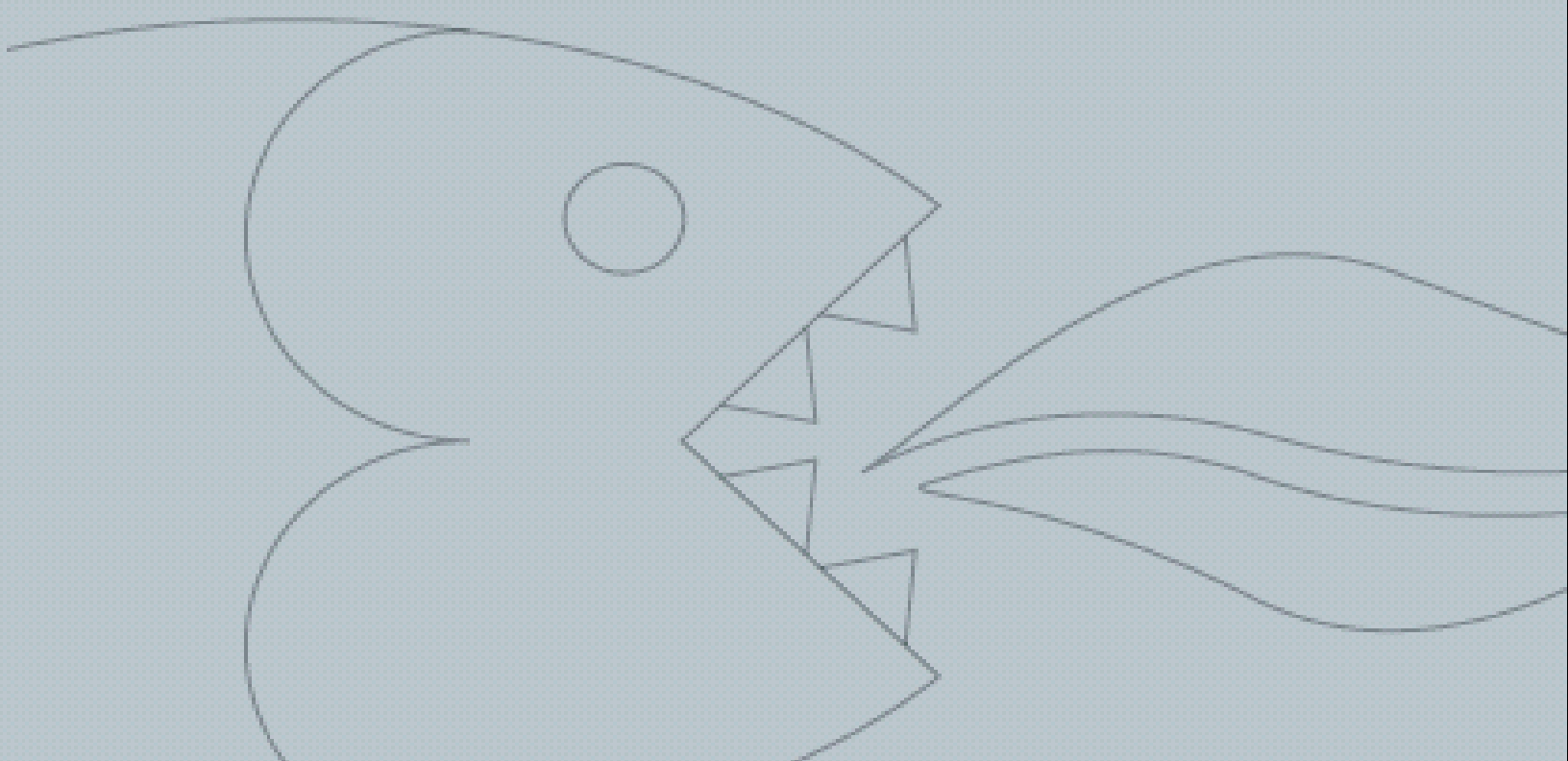

Baumatic

BTM25.2M Microwave Oven

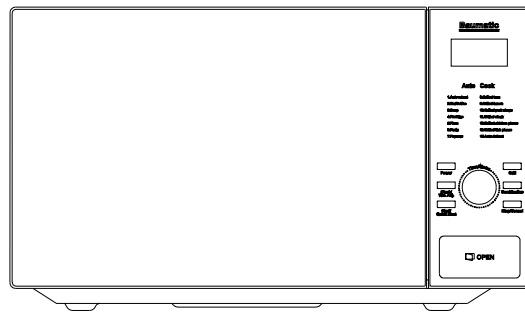

Instruction Manual

A NOTE TO YOU

Thank you for buying a Baumatic appliance.

Baumatic appliances are easy to use, save time, and help you manage your home better.

This manual contains valuable information about how to operate and maintain your Microwave properly and safely.

Please read it carefully.



WARNING!

Precautions to avoid possible exposure to excessive Microwave Energy:

- 1) **Do not** attempt to operate this oven with the door open since this can result in harmful exposure to microwave energy. It is important not to damage or tamper with the safety interlocks.
- 2) **Do not** place any object between the oven front face and the door or allow soil or cleaner residue to accumulate on sealing surfaces.
- 3) **Do not** operate the oven if it is damaged. It is particularly important that the oven door close properly and that there is no damage to the:
 - a. Door (bent),
 - b. Hinges and latches (broken or loosened),
 - c. Door seals and sealing surfaces.
- 4) The oven **should not** be adjusted or repaired by anyone except properly qualified service personnel.



PLEASE- ONLY HAVE A QUALIFIED PERSON INSTALL THIS APPLIANCE, ALL, REPAIRS MUST ONLY BE CARRIED OUT BY A BAUMATIC ENGINEER OR ITS AUTHORISED AGENTS OTHERWISE THIS WILL INVALIDATE YOUR WARRANTY.

TABLE OF CONTENTS:

MICROWAVE SPECIFICATIONS	5
INSTALLING YOUR OVEN	5
GROUNDING INSTRUCTIONS	6
RADIO INTERFERENCE	6
IMPORTANT SAFETY INSTRUCTIONS	7
MICROWAVE COOKING PRINCIPLES	9
UTENSILS GUIDE	9
MICROWAVE PART NAMES	10
CONTROL PANEL	12
HOW TO SET THE OVEN CONTROLS	13
OTHER CONVENIENT FEATURES	18
CLEANING AND CARE	19
BEFORE YOU CALL FOR SERVICE	20
GUARANTEE AND CONTACT DETAILS	21
BUILT UNDER INSTALLATION FOR YOUR MICROWAVE	22

DD 11/07/07

MICROWAVE SPECIFICATIONS

Power Consumption:	230V, 50Hz, 1400W (Microwave), 2000W (Convection) 1200 (Grill)
Rated Microwave Power Output:	900W
Operation Frequency:	2450MHz
Outside Dimensions:	310mm(H)x508mm(W)x450mm(D)
Oven Cavity Dimensions:	210mm(H)x338mm(W)x348mm(D)
Oven Capacity:	25Litres
Cooking Uniformity:	Turntable System { Φ 314mm }
Net weight:	Approx. 19Kg

INSTALLING YOUR OVEN

- 1) Make sure that all the packing materials are removed from the inside of the door.
- 2) **WARNING:** Check the oven for any damage: such as misaligned or bent doors, damaged door seals or sealing surfaces, broken or loose door hinges and latches. Also dents inside the cavity or on the door. If there is any damage, do not operate the oven and contact qualified service personnel.
- 3) The microwave oven must be placed on a flat, stable surface to hold its weight and the heaviest food likely to be cooked in the oven.
- 4) Do not place the oven where heat, moisture, or high humidity are generated, or near combustible materials.
- 5) For correct operation, the oven must have sufficient airflow. Allow 20cm of space above the oven, 10 cm at back and 5cm at both sides. Do not cover or block any openings on the appliance. Do not remove the feet.
- 6) Do not operate the oven without the glass tray, roller support, and shaft in their proper positions.
- 7) Make sure that the power supply cord is undamaged and does not run under the oven or over any hot or sharp surface.
- 8) The socket must be readily accessible so that it can be easily unplugged in an emergency.
- 9) Do not use the oven outdoors.

GROUNDING INSTRUCTIONS

PLEASE NOTE: This appliance must be grounded. This oven is equipped with a cord with a grounding wire and a grounding plug. It must be plugged into a wall receptacle that is properly installed and grounded. In the event of an electrical short circuit, grounding reduces risk of electrical shock by providing an escape wire for the electric current. It is recommended that a separate circuit serving only the oven be provided. **Using a high voltage is dangerous and may result in a fire or other accident causing oven damage.**

WARNING: Improper use of the grounding plug can result in a risk of electric shock.

Note:

- If you have any questions about the grounding or electrical instructions, consult a **qualified electrician or service person.**
- Neither the manufacturer nor the dealer can accept any liability for damage to the oven or personal injury resulting from failure to observe the electrical connection procedures.

- The wires in this cable main are colored in accordance with the following code:
Green & Yellow= EARTH
Blue= NEUTRAL
Brown= LIVE

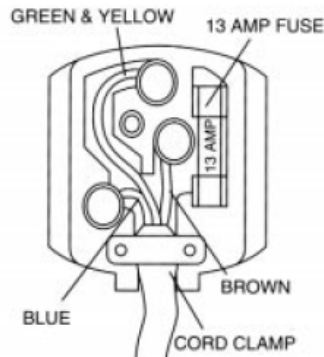

RADIO INTERFERENCE

Operation of the microwave oven can cause interference to your radio, TV, or similar equipment.

When there is interference, it may be reduced or eliminated by taking the following measures:

1. Clean door and sealing surface of the oven.
2. Reorient the receiving antenna of your radio or television.
3. Relocate the microwave oven with respect to the receiver.
4. Move the microwave oven away from the receiver.
5. Plug the microwave oven into a different outlet so that the oven and receiver are on different branch circuits.

IMPORTANT SAFETY INSTRUCTIONS



When using the electrical appliance basic safety precautions should be followed, including the following.

To reduce the risk of burns, electric shock, fire, injury to persons or exposure to excessive microwave energy:

- 1) Read all instructions before using the appliance.
- 2) Use this appliance only for its intended use as described in this manual. Do not use corrosive chemical or vapours in this appliance. This type of oven is specifically designed to heat, cook or dry food. It is not designed for industrial or laboratory use.
- 3) Do not operate the oven when empty.
- 4) Do not operate this appliance if it has a damaged cord or plug, if it is not working properly or if it has been damaged or dropped. If the supply cord is damaged, it must be replaced by the manufacturer or its service agent or a similarly qualified person in order to avoid a hazard.

WARNING: only allow children to use the oven without supervision when adequate instructions have been given so that the child is able to use the oven in a safe way and understands the hazards of improper use.

- 5) To reduce the risk of fire in the oven cavity:
 - a. When heating food in plastic or paper containers, keep an eye on the oven due to the possibility of ignition;
 - b. Remove wire twist-ties from paper or plastic bags before placing bag in oven.
 - c. If smoke is observed, switch off or unplug the appliance and keep the door closed in order to stifle any flames.
 - d. Do not use the cavity for storage purposes. Do not leave paper products, cooking utensils or food in the cavity when not in use.

WARNING: Liquid or other food must not be heated in sealed containers since they are liable to explode.

- 6) Microwave heating of beverages can result in delayed eruptive boiling; therefore care has to be taken when handling the container.
- 7) Do not fry food in the oven. Hot oil can damage oven parts utensils and even result in skin burns.

IMPORTANT SAFETY INSTRUCTIONS – CONT:

- 8) Eggs in their shell and whole hard boiled eggs should not be heated in microwave ovens as they may explode even after microwave heating has ended.
- 9) Pierce foods with heavy skins such as potatoes, whole squashes, apples and chestnuts before cooking.
- 10) The contents of feeding bottles and baby jars should be stirred and shaken and the temperature should be checked before serving in order to avoid burns.
- 11) Cooking utensils may become hot because of heat transferred from the heated food. Potholders may be needed to handle the utensil.
- 12) Utensils should be checked to ensure that they are suitable for use in a microwave oven.

WARNING: It is hazardous for anyone other than a trained person to carry out any service or repair operation which involves the removal of any cover which gives protection against exposure to microwave energy.

- 13) Group 2 ISM equipment: Group2 contains all ISM equipment in which radio-frequency energy is intentionally generated and/or used in the form of electromagnetic radiation for the treatment of material, and spark erosion equipment, e.g. Domestic microwave ovens are mentioned inside this scope under Annex. Class B equipment is suitable for use in domestic establishments directly connected to a low voltage power supply network which supplies buildings used for domestic purposes.

W.E.E.E Directive Compliance

This appliance is marked according to the European directive 2002/96/EC on Waste electrical and Electronic Equipment (WEEE). By ensuring this product is disposed of correctly, you will help prevent potential negative consequences for the environment and human health, which could otherwise be caused by inappropriate waste handling of this product.

The symbol  on the product, or on the documents accompanying the product, indicates that this appliance may not be treated as household waste. Instead it shall be handed over to the applicable collection point for the recycling of electrical and electronic equipment.

Disposal must be carried out in accordance with local environmental regulations for waste disposal.
For more detailed information about treatment, recovery and recycling of this product, please contact your local city office, your household waste disposal service or the shop where you purchased the product.

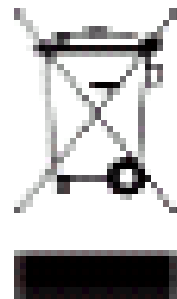

MICROWAVE COOKING PRINCIPLES

- Arrange food carefully. Place thickest areas towards outside of dish.
- Watch cooking time. Cook for the shortest amount of time indicated and add more as needed. Food severely overcooked can smoke or ignite.
- Cover foods while cooking. Covers prevent spattering and help foods to cook evenly.
- Turn foods over once during microwaving to speed cooking of such foods as chicken and hamburgers. Large items like roasts must be turned over at least once.
- Rearrange foods such as meatballs halfway through cooking both from top to bottom and from the centre of the dish to the outside.

UTENSILS GUIDE

- The ideal material for a microwave utensil is transparent to microwaves, it allows energy to pass through the container and heat the food.
- Microwave can not penetrate metal, so metal utensils or dishes with metallic trim should not be used.
- Do not use recycled paper products when microwave cooking, as they may contain small metal fragments which may cause sparks and/or fires.
- Round/oval dishes rather than square/oblong ones are recommended, as food in corners tends to overcook.
- Narrow strips of aluminium foil may be used to prevent overcooking of exposed areas. But be careful to not use too much and keep a distance of 1 inch (2.54cm) between foil and cavity.

The list on the following page is a general guide to help you select the correct utensils:

UTENSILS

Cookware	Microwave	Grill	Convection	Combination*
Heat-resistant glass	Yes	Yes	Yes	Yes
Non heat – resistant glass	No	No	No	No
Heat – resistant Ceramics	Yes	Yes	Yes	Yes
Microwave – safe Plastic dish	Yes	No	No	No
Kitchen paper	Yes	No	No	No
Metal Tray	No	Yes	Yes	No
Metal Rack	No	Yes	Yes	No
Aluminium Foil and Foil containers	No	Yes	Yes	No

* **Combination:** Applicable for both “Microwave + Grill” and “Microwave + Convection” cooking.

MICROWAVE PART NAMES

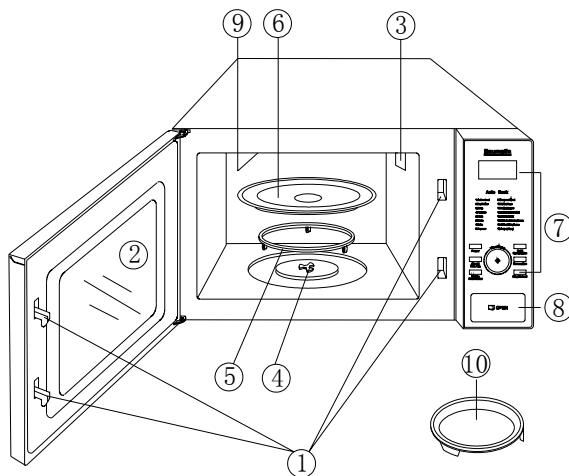

1. Door safety lock system
2. Oven Window
3. Oven Air Vent
4. Shaft
5. Roller Ring
6. Glass Tray
7. Control Panel
8. Door Release button
9. Grill Heater
10. Baking Plate

CONTROL PANEL

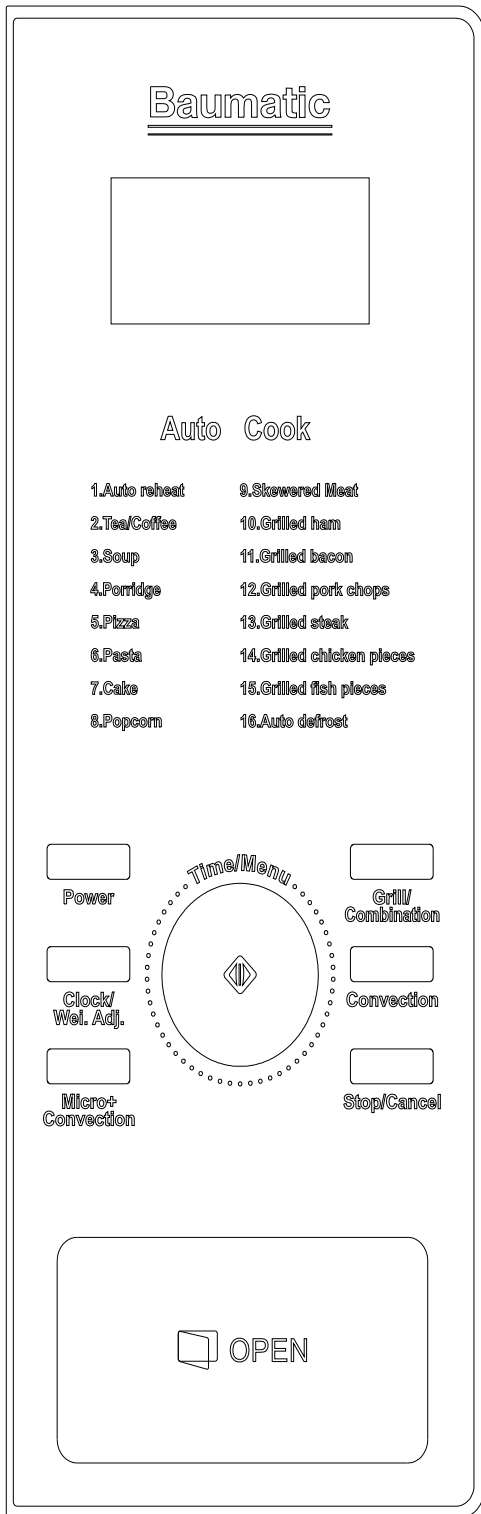

DISPLAY SCREEN:

Cooking time, power, programme indicators and clock time are shown

POWER:

Press to select Microwave power level.

GRILL/COMBINATION:

Press to set a grill or combination cooking program.

CONVECTION:

Press to program convection temperature.

MICRO + CONVECTION:

Press to select one of four combination cooking settings.

TIME/MENU (DIAL):

Rotate to set the clock or to set food weight

CLOCK/WEI.ADJ

Press to set the clock or set food weight.

(START/QUICKSTART)

Press to set the cooking program or set quick start cooking programme.

STOP/CANCEL

Touch to stop cooking programme or clear all previous settings before cooking starts.

(Please also see the following pages for more detail)

HOW TO SET THE OVEN CONTROLS

BEEPS DURING OVEN SETTINGS

- **ONE BEEP:** Oven accepts the entry.
- **TWO BEEPS:** Oven does not accept the entry. Please check and try again.

SETTING THE CLOCK

1. Press and hold CLOCK/WEI.ADJ. button for 3 seconds, "H24" displays. Press this button again, the oven turn to 12-hour system.
2. Rotate the TIME/MENU dial until the correct hour is displayed.
3. Press CLOCK/WEI.ADJ. button.
4. Rotate the TIME/MENU dial until the correct minute is displayed.
5. Press CLOCK/WEI.ADJ. button to confirm.

MICROWAVE

Microwave cooking allows you to customize cooking power and time. First, you select a power level by pressing the POWER button a number of times (see the table below). Then you set the cooking time by rotating the TIME/MENU dial, before pushing START.

Press POWER button to select cooking power		
Press	Power	Description
Once	100% (P-HI)	High
Twice	90% (P-90)	
3 times	80% (P-80)	
4 times	70% (P-70)	Medium High
5 times	60% (P-60)	
6 times	50% (P-50)	Medium
7 times	40% (P-40)	
8 times	30% (P-30)	Med Low/Defrost
9 times	20% (P-20)	
10 times	10% (P-10)	Low
11 times	0% (P-00)	

Suppose you want to cook for 5 minute at 60% power level:

1. Press POWER button 5 times.
2. Rotate the TIME/MENU dial until the correct cooking time is displayed.
3. Press START.

NOTE:

1. If you want to temporarily stop a cooking session, press STOP/CANCEL once and then you can start the cooking again by pressing START; or press STOP/CANCEL twice to cancel the cooking program altogether.
2. After the cooking time ends, the system will beep four times and END is displayed. Before starting another cooking session, you need to clear the display and reset the system by pressing the STOP/CANCEL button.

HOW TO SET THE OVEN CONTROLS

GRILL

Grill cooking is particularly useful for thin slices of meat, steaks, chops, kebabs, sausages and pieces of chicken.

Suppose you want to program grill cooking for 12 minutes.

1. Make sure the system is reset, which means no current cooking program is running, and the system is waiting for instructions.
2. Press GRILL/COMBINATION button once.
3. Turn the TIME/MENU to 12:00.
4. Press START.

NOTE:

Grill cooking power is set at full power level by the system.

MICROWAVE +GRILL

This feature allows you to combine grill and microwave cooking on two different settings. First, press this button twice or three times to choose an appropriate combination setting, then, at the screen prompt, enter the desired cooking time by turning the TIME/MENU dial. After you have pushed the start button, the system begins to count down.

NOTE:

During cooking, you can see the programmed setting by pressing this button.

COMBINATION 1

30% time for microwave cooking, 70% for grill cooking. Use for fish, potatoes or au gratin.

Suppose you want to set combination 1 cooking for 25 minutes.

1. Press STOP/CANCEL button.
2. Press GRILL/COMBINATION button twice.
3. Turn TIME/MENU to 25:00.
4. Press START.

COMBINATION 2

55% time for microwave cooking, 45% for grill cooking. Use for pudding, omelets, baked potatoes and poultry.

Suppose you want to set combination 2 cooking for 12 minutes.

1. Press STOP/CANCEL button.
2. Press GRILL/COMBINATION button three times.
3. Turn TIME/MENU to 12:00.
4. Press START.

HOW TO SET THE OVEN CONTROLS

CONVECTION

During convection cooking, hot air is circulated throughout the oven cavity to brown and make crisp foods quickly and evenly. This oven can be programmed for ten different cooking temperatures.

To Cook with Convection

Press CONVECTION button to set convection temperature.

Press	TEMPERATURE(°C)
Once	230
Twice	215
3 times	200
4 times	185
5 times	170

Suppose you want to cook at 185°C for 40 minutes.

1. Press CONVECTION button 4 times.
2. Rotate the TIME/MENU dial until the correct cooking time is displayed.
3. Press START.

NOTE:

1. After time has elapsed four beeps sound and END appears in display.
2. You can check the convection temperature while cooking is in progress by pressing the CONVECTION button.

To Preheat and Cook with Convection

Your oven can be programmed to combine preheating and convection cooking operations.

Suppose you want to preheat to 170°C and then cook for 35 minutes.

1. Press CONVECTION button 5 times.
2. Press START. One beep will sound and "PREH" will flicker in the display until the oven reaches the programmed temperature.
3. Open the door and place container of food at the center of the turntable.
4. Rotate the TIME/MENU dial to program cooking time.
5. Press START.

HOW TO SET THE OVEN CONTROLS

MICROWAVE +CONVECTION

This oven has four pre-programmed settings that make it easy to cook with both convection heat and microwave automatically.

Press MICRO+CONVECTION button to select convection temperature:

	Press	Oven temperature(°C)
COMB1	Once	230
COMB2	Twice	200
COMB3	3 times	180
COMB4	4 times	150

Suppose you want to bake a cake for 24 minutes on COMB3.

1. Press MICRO+CONVECTION button 3 times.
2. Rotate the TIME/MENU dial to program cooking time.
3. Press START to begin.

NOTE:

After time has elapsed four beeps sound and END appears in display. Press STOP/CANCEL button or open door to clear END before starting another cooking function. You can check the convection temperature while cooking is in progress by pressing the MICRO+CONVECTION button.

SPEED DEFROST

Suppose you want to defrost frozen food for five minutes.

1. Rotate the TIME/MENU dial until "A-16" and "CODE" is displayed.
2. Press CLOCK/WEI.ADJ. button.
3. Rotate the TIME/MENU dial to program defrosting time.
4. Press START.

NOTE:

1. For either raw or previously cooked frozen food the rule is approximately 8-12 minutes per pound. For example, defrost 8-12 minutes for 1 pound of frozen spaghetti sauce.
2. Always stop the oven periodically to remove or separate the portions that are defrosted. If food is not defrosted at the end of the estimated defrosting time, program the oven in 1-minute increments until totally defrosted.
3. When using plastic containers from the freezer, defrost only long enough to remove from plastic in order to place in a microwave-safe dish.

MULTI-STAGE COOKING

Your oven can be programmed for up to 3 automatic cooking sequences.

Suppose you want to set the following cooking program:

DEFROST - MICROWAVE COOKING -CONVECTION COOKING (without preheat function)

1. Rotate the TIME/MENU dial until "**A-16**" and "**CODE**" is displayed.
2. Press CLOCK/WEI. ADJ. button.
3. Rotate the TIME/MENU dial to program defrosting time.
4. Press POWER button to set power level.
5. Rotate the TIME/MENU dial to program cooking time.
6. Press CONVECTION button to set convection temperature.
7. Rotate the TIME/MENU dial to program cooking time.
8. Press START.

HOW TO SET THE OVEN CONTROLS

MENU COOK

The system has 16 menus. In waiting mode, rotate the dial to select a food code (see the table below) and then press the CLOCK/WEI.ADJ. to confirm, rotate the dial again to select weight or number of serving and finally press START to begin cooking.

1. Rotate TIME/MENU anti-clockwise to select food code for the food to be cooked.
2. Press CLOCK/WEI.ADJ. continually to select the amount.
3. Press START.

AUTO COOK CODE/MENU (more information can be found under the table)

AUTO MENU		Press CLOCK/WEI.ADJ., to indicate number of servings						
		1	2	3	4	5	6	7
A- 01	Auto reheat	200g	300g	400g	500g	600g	700g	800g
A- 02	Tea/coffee (200ml/cup)	1cup	2cups	3cups				
A- 03	Soup(200ml/soup)	1soup	2soups	3soups				
A- 04	Porridge	50g	100g	150g				
A- 05	Pizza(5°C)	150g	300g	450g				
A- 06	Pasta	100g	200g	300g				
A- 07	Cake	40:00 (tolerant weight 475g)						
A- 08	Popcorn	3:45 (tolerant weight 3.5oz)						
A- 09	Skewered Meat	200g	300g	400g	500g	600g		
A- 10	Grilled ham	100g	200g	300g	400g	500g		
A- 11	Gilled bacon	100g	200g	300g	400g	500g		
A- 12	Grilled pork chops	200g	300g	400g	500g	600g		
A- 13	Grilled steak	200g	300g	400g	500g	600g		
A- 14	Grilled chicken pieces	200g	300g	400g	500g	600g		
A- 15	Grilled fish pieces	200g	300g	400g	500g	600g		
A- 16	Auto defrost							

Note:

1. For CAKE (7) and POPCORN (8), you may reset the cooking time if the default cooking time is not appropriate. To reset the cooking time: Rotate the TIME/MENU dial until the food code is displayed, press CLOCK/WEI.ADJ. button twice, rotate the Time/Menu dial to program the new cooking time, and then press START to verify. The new cooking time will remain whenever you use the CAKE function until you reset it again.
2. To cook in grill or combination mode, you may need to turn food over in the middle of cooking time for uniform cooking result.

OTHER CONVENIENT FEATURES

CHILD PROOF LOCK

The child proof lock prevents unsupervised operation by children.

To set the child proof lock: Press STOP/CANCEL button for 3 seconds, then a beep will sound and the indicator light will come on. In the lock state, all buttons are disabled.
To cancel the child proof lock: Press STOP/CANCEL button for three seconds, then a beep will sound and the indicator light will come off.

QUICK START

Use this feature to program the oven to microwave food at 100% power conveniently. Press START in quick succession to set the cooking time. The maximum cooking time is 10 minutes. The oven will auto-start two seconds later. After time has elapsed four beeps sound and END appears in display.

TO STOP THE OVEN WHILE THE OVEN IS OPERATING

1. Press STOP/CANCEL button.
You can restart the oven by pressing START pad.
Touch STOP/CANCEL to erase all instructions.
2. Open the door.
You can restart the oven by closing the door and pressing START pad.

NOTE:

Oven stops operating when door is opened.

OVERHEATING PROTECTION

During cooking, when the temperature of the cavity reaches over 300 °C, the display will show E 01 with a buzzer sounding. To deal with the problem press the STOP/CANCEL button, the oven will be back to normal.

LOW TEMPERATURE PROTECTION

5 minutes after convection or convection and microwave combination cooking starts, if the temperature of cavity is lower than 40 °C, the system will enter low temperature protection, the display shows E 02, buzzer will sound. To deal with the problem: press the CANCEL button, the oven will be back to normal.

SENSOR MALFUNCTION PROTECTION

In case of a short, the system enters into malfunction protection. The display shows E 03 buzzer will sound. To deal with the problem: press the STOP/CANCEL button, the oven will be back to normal.

CLEANING AND CARE:

- Turn off the oven and remove the power plug from the wall socket before cleaning.
- Keep the inside of the oven clean. When food splatters or spilled liquids adhere to oven walls, wipe with a damp cloth. Mild detergent may be used if the oven gets very dirty. Avoid the use of spray and other harsh cleaners as they may stain, streak or dull the door surface.
- The outside surfaces should be cleaned with a damp cloth. To prevent damage to the operating parts inside the oven, water should not be allowed to seep into the ventilation openings.
- Wipe the door and window on both sides, the door seals and adjacent parts frequently with a damp cloth to remove any spills or splatters. Do not use abrasive cleaner.
- Do not allow the control panel to become wet. Clean with a soft, damp cloth. When cleaning the control panel, leave the oven door open to prevent oven from accidentally turning on.
- If steam accumulates inside or around the outside of the oven door, wipe with a soft cloth. This is normal and may occur when the microwave oven is operated under a high humidity condition.
- It is occasionally necessary to remove the glass tray for cleaning. Wash the tray in warm sudsy water or in a dishwasher.
- The roller ring and oven floor should be cleaned regularly to avoid excessive noise. Simply wipe the bottom surface of the oven with mild detergent. The roller ring may be washed in mild soapy water or dishwasher. When removing the roller ring from the cavity floor for cleaning, be sure to replace in the proper position.
- Remove doors from your oven by combining a cup of water with the juice and skin of one lemon in a deep microwaveable bowl, microwave for 5 minutes. Wipe thoroughly and dry with a soft cloth.
- When it becomes necessary to replace the oven light, please consult a dealer to have it replaced.

BEFORE YOU CALL FOR SERVICE:

If the oven fails to operate:

- Check to ensure that the oven is plugged in securely. If it is not, remove the plug from the outlet, wait 10 seconds, and plug it in again securely.
- Check for a blown circuit fuse or a tripped main circuit breaker. If these seem to be operating properly, test the outlet with another appliance.
- Check to ensure that the control panel is programmed correctly and the timer is set.
- Check to ensure that the control panel is programmed correctly and the timer is set.
- Check to ensure that the door is securely closed engaging the door safety lock system. Otherwise, the microwave energy will not flow into the oven.

IF NONE OF THE ABOVE RECTIFIES THE SITUATION, THEN CONTACT A QUALIFIED TECHNICIAN (SEE PAGE 23). DO NOT TRY TO ADJUST OR REPAIR THE OVEN YOURSELF.

SCHEMATIC DIAGRAM

NOTE: Door is closed
Unit is not operated

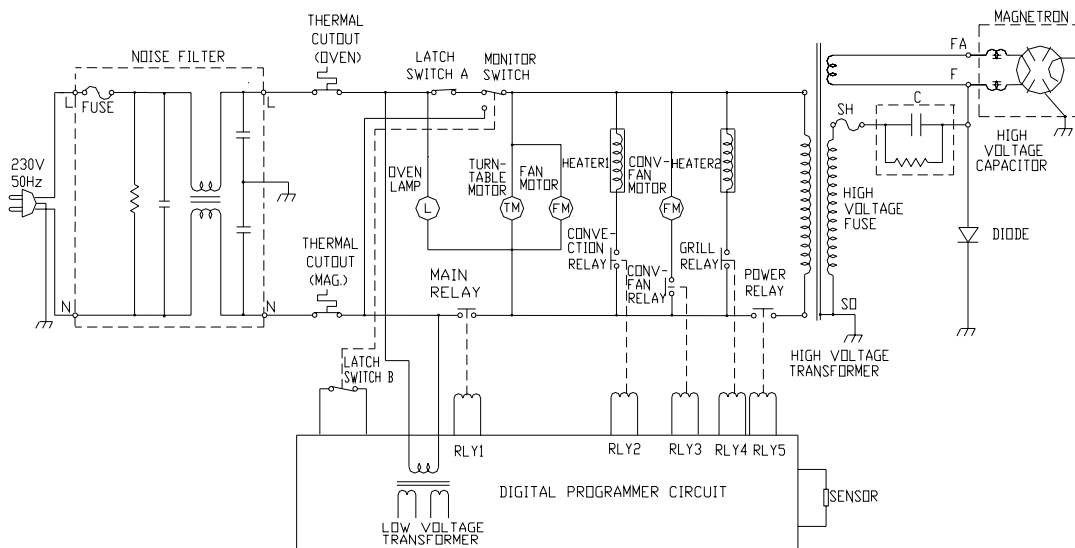

Built under installation for your microwave.

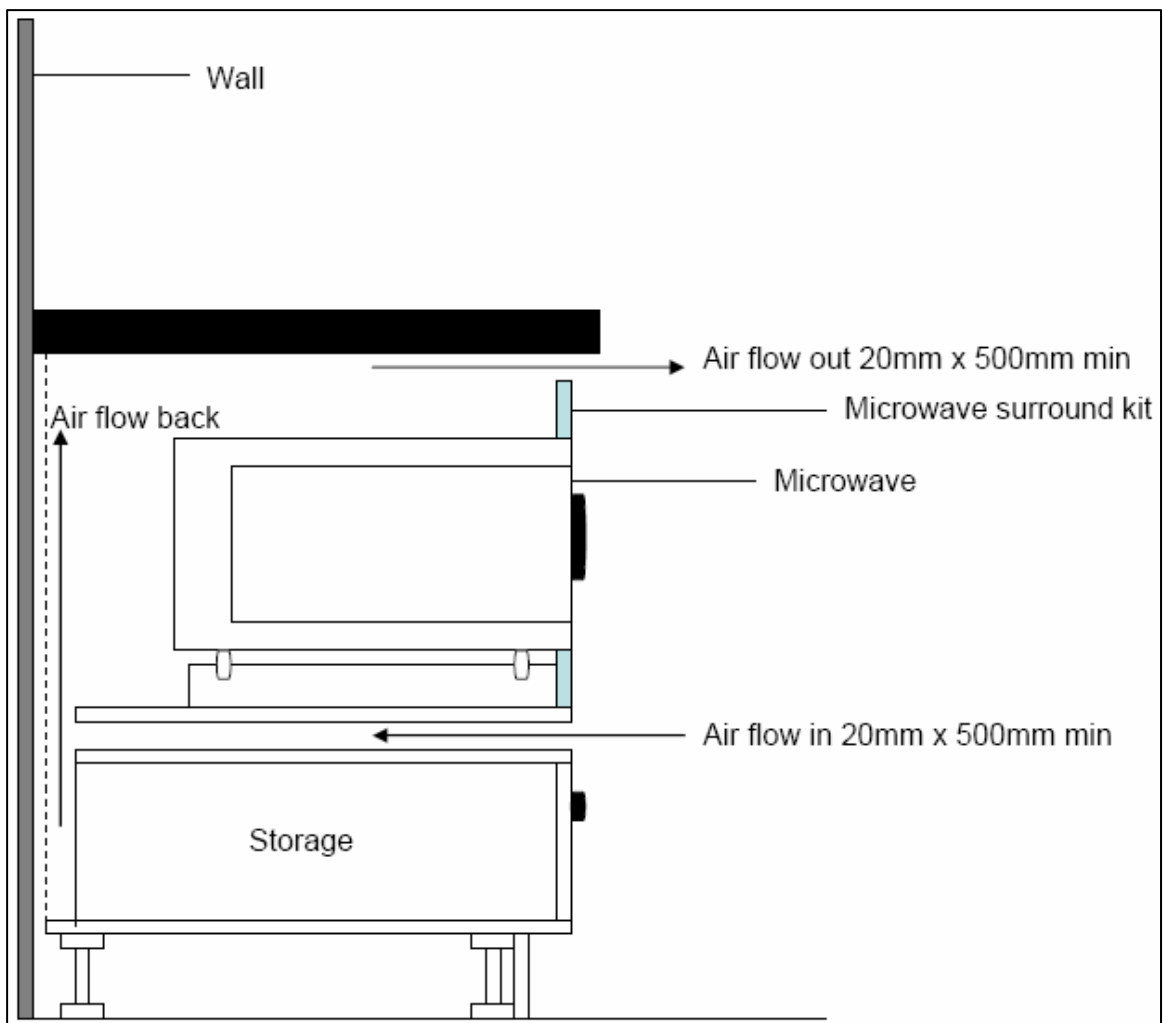
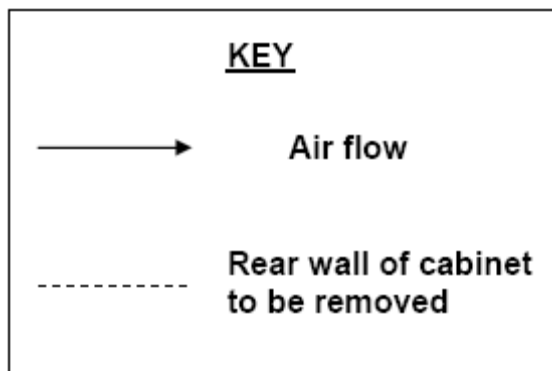

IMPORTANT: NO OTHER METHODS OF BUILDING UNDER THE MICROWAVE ARE SANCTIONED BY BAUMATIC.

Built under installation for your microwave.

It is possible to build your microwave under a worktop; however the following installation MUST be followed:-

1. The rear wall of the housing unit MUST be removed to allow there to be the correct amount of ventilation.
2. The ventilation gaps below the support shelf and below the worktop MUST be adhered to.
3. The appropriate Baumatic Microwave Building In Kit MUST be fitted.
4. An induction hob MUST NOT be fitted above the microwave.
5. It is not necessary for there to be a storage drawer fitted underneath the microwave; this is shown purely as an example in the drawing on the preceding page.
6. **WARNING: The microwave will get hot during operation; care should be taken not to accidentally come into contact with the outer surface.**
7. **WARNING: Children should not be allowed near to the appliance unsupervised.**

Baumatic Ltd. Conditions of guarantee

Dear Customer,

Your new Baumatic appliance comes complete with a free 12 month guarantee covering both parts and labour costs resulting from defective materials or workmanship.

Baumatic also gives you the opportunity to automatically extend the guarantee period for a further 12 months at no extra cost, giving an initial guarantee period of 24 months. The extended guarantee period applies to England, Scotland, Wales and Northern Ireland only.

To qualify for your full 24 months guarantee you **must** register your appliance within 28 days of purchase to be covered under this guarantee. This can be done online via: www.baumatic.co.uk or through returning the guarantee card which can be found in each new Baumatic appliance.

* In addition, your appliance is covered by a 5 year parts warranty. Baumatic Ltd will provide free of charge the parts required to repair the appliance, only if they are fitted by a Baumatic engineer, for any defect that arises due to faulty materials or workmanship within a period of 5 years from the original purchase date.

* An additional 1 to 3 year insurance scheme for labour is available should you wish to extend the warranty period.

Should any person other than an authorised representative of Baumatic Ltd interfere with the appliance, the policy is negated and Baumatic Ltd will be under no further liability.

The guarantee covers the appliance for normal domestic use only, unless otherwise stated.

Any claims made under the terms of the guarantee must be supported by the original invoice/bill of sale issued at the time of purchase.

This guarantee is transferable only with the written consent of Baumatic Ltd.

If the appliance fails and is considered either not repairable or uneconomical to repair between 12 months (2 years if registered) and five years, a free of charge replacement will not be offered.

The guarantee for any replacement will only be for the remainder of the guarantee on the original product purchased.

The guarantee does not cover:

- Sinks and taps
- Failure to comply with the manufacturers instructions for use.
- The replacement of cosmetic components of accessories
- Accidental damage or wilful abuse.
- Subsequent loss or damage owing to the failure of the appliance or electrical supply
- Incorrect installation
- Losses caused by Acts of God, civil war, failure to obtain spare parts, strikes or lockouts
- Filters, fuses, light bulbs, external hoses, damage to bodywork, paintwork, plastic items, covers, baskets, trays, shelves, burner bases, burner caps, decals, corrosion, rubber seals.

In the course of the work carried out it may be necessary to remove the appliance from it operating position. Whilst all reasonable care will be taken, Baumatic Ltd cannot accept responsibility for damage sustained to any property whatsoever in this process.

This guarantee is in addition to and does not diminish your statutory or legal rights.

Contacting Baumatic Ltd

Sales	Service	Spares	Technical/Advice
TEL: 0118 933 6900	TEL: 0118 933 6911	TEL: 0118 933 6922	0118 933 6933
FAX: 0118 931 0035	FAX: 0118 986 9124	FAX: 0118 933 6942	0118 933 6942

For ROI (Republic of Ireland), please contact one of the numbers below:

TEL: 01 – 6266798 FAX: 01 - 6266634

Thanks you for buying Baumatic.

* Applies to UK, Scotland, Wales & Northern Ireland only (Republic of Ireland has 1 year labour & 1 year parts warranty only)



You will be mine ...

Headquarters

Baumatic Ltd.
Baumatic Buildings,
6 Bennet Road,
Reading,
Berkshire
RG2 0QX, United Kingdom

Sales Telephone
+44 118 933 6900

Sales Fax
+44 118 931 0035

Service Telephone
+44 118 933 6911

Service Fax
+44 118 986 9124

Spares Telephone
+44 118 933 6922

Technical / Advice Telephone
+44 118 933 6933

E-mail:

sales@baumatic.co.uk

technical@baumatic.co.uk

Http (Internet site):
www.baumatic.com



Baumatic®

www.baumatic.com